

*Please read this manual carefully before setting-up and using your unit*

# AnchorZip10

## Operator Manual

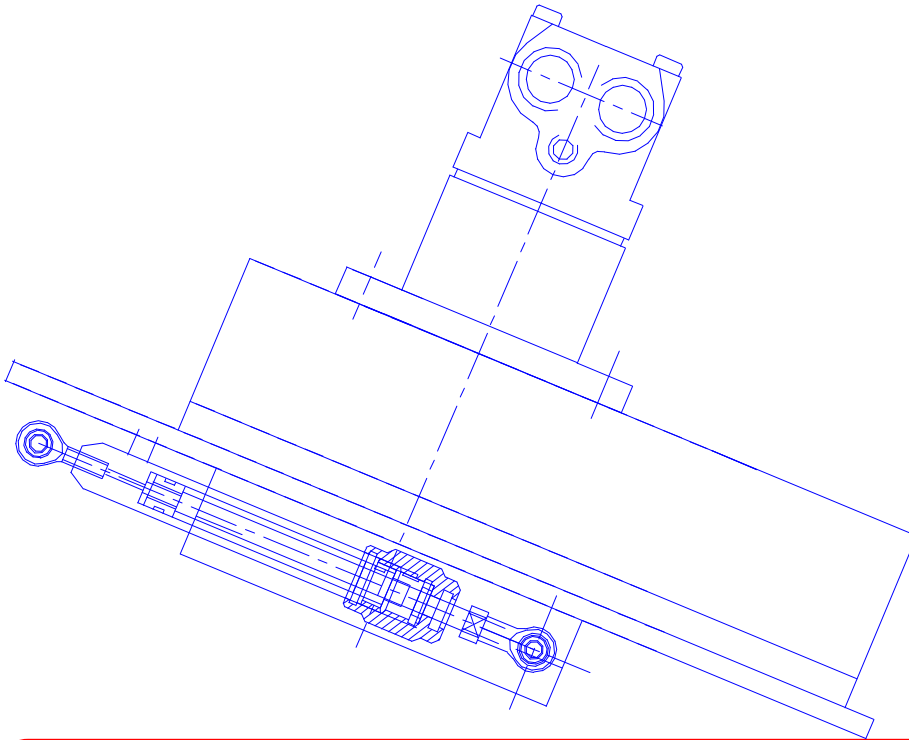

**The electronic version of this document is the controlled copy. Therefore all printed versions of this document are uncontrolled.**

**For the latest manual revision always visit “[www.tritech.co.uk](http://www.tritech.co.uk)”**

## COPYRIGHT

© Tritech International Limited

The copyright in this document is the property of Tritech International Limited. The document is supplied by Tritech International Limited on the understanding that it may not be copied, used, or disclosed to others except as authorised in writing by Tritech International Limited.

Tritech International Limited reserves the right to change, modify and update designs and specifications as part of their ongoing product development programme.

**CONTENTS**

<b>WARRANTY POLICY</b>	<b>5</b>
<b>SAFETY STATEMENTS &amp; CE MARKING</b>	<b>6</b>
<b>TECHNICAL SUPPORT</b>	<b>7</b>
<b>INTRODUCTION</b>	<b>8</b>
<b>SPECIFICATION</b>	<b>8</b>
Hydraulic Input	8
Pressure/Suction Performance	8
General	8
GA Drawing	9
<b>INSTALLATION</b>	<b>10</b>
Mechanical Installation	10
Water Hose Installation (if needed)	10
Hydraulic Installation.	10
Hydraulic Hook-up.	11
Fittings	11
Required Hydraulic Flow	12
<b>Testing In Air</b>	<b>13</b>
Hydraulic motor shaft seals	13
<b>CORRECT OPERATION OF THE ANCHORZIP PUMP</b>	<b>14</b>
Achieving differential suction pressures in shallow water	15
Example : Depth versus suction capability	16
<b>MAINTENANCE</b>	<b>17</b>
Basic maintenance procedures	17
Pre- Dive	17
Storage	17
Basic Fault Finding	18
Dismantling	18
Reverse valve actuators	18
Relief valve slipper ring and setting relief pressure	18
Setting relief pressure	19
Assembling the Interface Block	21
Hydraulic Motor and Impeller	23
<b>PARTS DIAGRAM</b>	<b>24</b>
Parts List	25
<b>APPENDIX 1</b>	<b>26</b>
Tritech Volvo Protector.	26
<b>APPENDIX 2</b>	<b>28</b>
Performance Curves	28

**WARRANTY POLICY**

**Tritech International Limited** herein after referred to as **TIL**

TIL warrants that at the time of shipment all products shall be free from defects in material and workmanship and suitable for the purpose specified in the product literature.

The unit/system warranty commences immediately from the date of customer acceptance and runs for a period of 365 days. Customer acceptance will always be deemed to have occurred within 72 hours of delivery.

**Note:** Any customer acceptance testing (if applicable) must be performed at either TIL premises or at one of their approved distributors unless mutually agreed in writing prior to despatch.

**Conditions:**

**These include, but are not limited to, the following:**

- 1 The warranty is only deemed to be valid if the equipment was sold through TIL or one of its approved distributors.
- 2 The equipment must have been installed and commissioned in strict accordance with approved technical standards and specifications and for the purpose that the system was designed.
- 3 The warranty is not transferable, except or as applies to Purchaser first then to client.
- 4 TIL must be notified immediately (in writing) of any suspected defect and if advised by TIL, the equipment subject to the defect shall be returned by the customer to TIL, via a suitable mode of transportation and shall be freight paid.
- 5 The warranty does not apply to defects that have been caused by failure to follow the recommended installation or maintenance procedures. Or defects resulting from normal wear & tear, incorrect operation, fire, water ingress, lightning damage or fluctuations in vehicles supply voltages, or from any other circumstances that may arise after delivery that is out with the control of TIL.  
(**Note:** The warranty does not apply in the event where a defect has been caused by isolation incompatibilities.)
- 6 The warranty does not cover the transportation of personnel and per diem allowances relating to any repair or replacement.
- 7 The warranty does not cover any direct, indirect, punitive, special consequential damages or any damages whatsoever arising out of or connected with misuse of this product.
- 8 Any equipment or parts returned under warranty provisions will be returned to the customer freight prepaid by TIL.
- 9 The warranty shall become invalid if the customer attempts to repair or modify the equipment without appropriate written authority being first received from TIL.
- 10 TIL retains the sole right to accept or reject any warranty claim.
- 11 Each product is carefully examined and checked before it is shipped. It should therefore be visually and operationally checked as soon as it is received. If it is damaged in anyway, a claim should be filed with the courier and TIL notified of the damage.



**Note:** TIL reserve the right to change specifications at any time without notice and without any obligation to incorporate new features in instruments previously sold.

**Note:** If the instrument is not covered by warranty, or if it is determined that the fault is caused by misuse, repair will be billed to the customer, and an estimate submitted for customer approval before the commencement of repairs.

## SAFETY STATEMENTS & CE MARKING

*The installation of the pump is fully the responsibility of the user. It is powered by high pressure hydraulics and contains moving parts. Full consideration has been given to the requirements for CE marking and the relevant safety information is contained within this manual. Since the pump as supplied as a subsystem and its safe use is installation specific, actual compliance is the responsibility of the installer. It must be operated in accordance with the following instruction manual.. Failure to follow the recommendations of this manual may lead to safety hazards or equipment failure.*



 <b>NOTE</b>	<p><i>Throughout the manual certain potential problems, or further information relating to the installation, maintenance, understanding or use of the apparatus will be highlighted to the operator by indications identified by the adjacent symbol and text.</i></p>
 <b>CAUTION</b> <b>!</b>	<p><i>Throughout the manual certain safety or operational related comments and requirements will be highlighted to the operator by indications identified by the adjacent symbol and text.</i></p>
 <b>DANGER!</b>	<p><i>Throughout the manual certain safety or operational related comments and requirements that could lead to injury or loss of life will be highlighted by the adjacent symbol and text.</i></p>

## TECHNICAL SUPPORT

Contact your local agent or Tritech International Ltd

	Mail	<b><i>Tritech International Ltd.</i></b> Peregrine Road, Westhill Business Park, Westhill, Aberdeen, AB32 6JL, UK
	Telephone	++44 (0)1224 744111
	Fax	++44 (0)1224 741771
	Email	support@tritech.co.uk
	Web	www.tritech.co.uk

**An out-of-hours emergency number is available by calling the above telephone number**

If you have cause to use our Technical Support service, please ensure that you have the following details at hand **prior** to calling:

- System Serial Number ( if applicable )
- Fault Description
- Any remedial action implemented
- Software Revision (if applicable)

Due to the expansion of equipment capabilities and the fact that new sub-modules are continually being introduced, this manual cannot detail every aspect of the operation.

## INTRODUCTION

The AnchorZip 10 is designed as a high efficiency water pump for moving large quantities of water at relatively low pressures. Its main application is in the deployment and retrieval of suction anchors and piles. The AnchorZip10 has been designed to close couple to a flange plate to provide the minimum of flow restrictions. Switching the flow from suction to blowing is achieved by sliding the whole pump and motor body. The AnchorZip10 also incorporates a suction break relief valve which, on the latest version, can be preset for pressures between 0.81 and 9.27 bar (*earlier versions of the pressure relief valve allowed 0.95 to 4.1Bar with an option to go higher with no relief.*)

## SPECIFICATION

### Hydraulic Input

Pressure (maximum)	4000psi	276bar
Flow (maximum)	15gpm	70l/min
Fittings	Motor ports A & B	No 12JIC male
	Motor case drain	No 6 JIC male
	Reverse actuators	No 4 JIC male

### Pressure/Suction Performance

Differential Pressure	Up to 140psi	9.5bar
Flow	Up to 80m <sup>3</sup>	@ 7.5bar
Suction relief	0.81 to 9.27 bar adjustable by spring quantity and valve ring selection	

### General

Motor type Volvo F11-10

Anchor port connection Square flange with 72mm diameter port (2.8") with 4 each M16 threaded holes on 150mm PCD

Water hose diameter 72mm (2.8") ID minimum

Reverse actuator pressure 1000psi 70bar minimum

Weight in air	66lbs	30kg
Weight in water	31lbs	14kg

Materials Stainless Steel, Nylacast, UHMWPE

Dimensions see GA drawing

GA Drawing

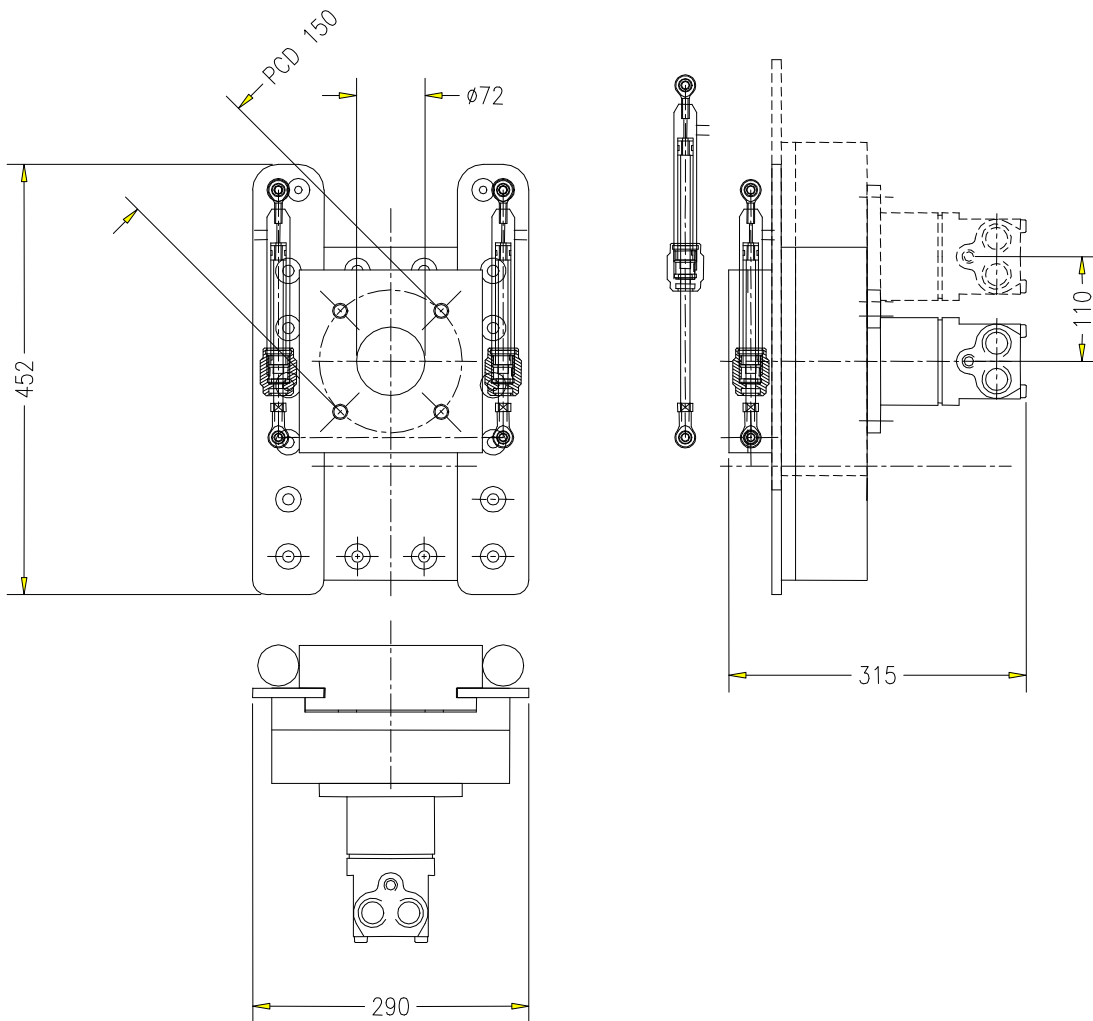



## INSTALLATION

 <b>DANGER!</b>	<p><i>Do not power up the pump or hydraulic valve actuators until all hoses are properly connected to the pump.</i></p> <p><i>There is a serious risk of injury to fingers if inserted into the water port.</i></p> <p><i>If the user wishes to power up the motor or actuator before the installation is complete it is his responsibility to ensure that suitable safety measures are in place to prevent injury.</i></p>
---	---

### Mechanical Installation

The pump may be mounted in any orientation on the vehicle, but it is recommended that the connection to the anchor be as direct and short as possible to avoid inhibiting the flow. The mounting flange carries the full weight of the pump unit and must therefore be adequately strong for this task.

The face of the pump carries 4 M16x2.0 mounting holes on a 150mm PCD. Bolts are installed through the installation flange into the pump interface. The pump mounting face is flat and the mating flange can either carry an “O”ring or a flat gasket. A 156 “O” ring seal groove is cut into the material for operating at higher pressures. Thread engagement should be between 45mm min and 48mm max. and tightening torque should be in the range 45-55Nm (33-40lb.ft) when using a copper slip or similar grease to avoid galling.

Grade 70 or higher bolts are recommended.

Sufficient space should be allowed to permit the pump body including motor to slide through a distance of 110mm to switch between suction and blowing.

### Water Hose Installation (if needed)

It is recommended that if possible the pump is close coupled to the anchor by a direct flange fitting or short sections of hard hose. Any flexible hose used must be suitably rated for the expected pressure differentials. Large diameter flexible hose is liable to collapse under suction.

### Hydraulic Installation.

#### Hydraulic oil

The pump should be operated using a premium grade mineral based hydraulic oil of ISO VG 22 to 32.

**Filtration**

The hydraulic system filtration must be to a minimum of 10um absolute standard. A 10um nominal standard is regarded as inadequate. The recommended filtration is UN elements produced by Pall Industrial Hydraulics Ltd. or equivalent products.

**Hydraulic Hook-up.**

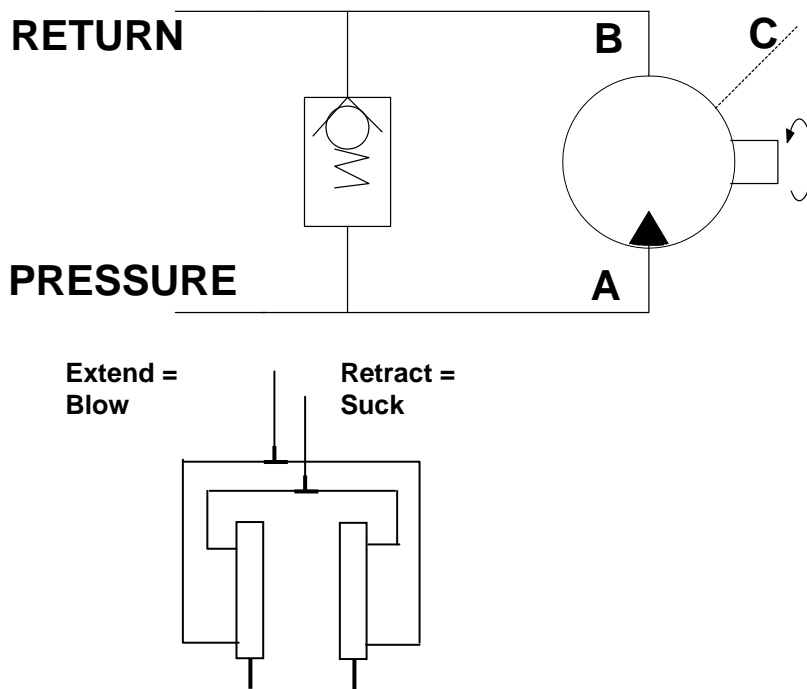

**Note:- If mounting restrictions dictate, it is possible to rebuild the pump with Retract= Blow and Extend=Suck. If required contact Tritech Technical support for details**

**Fittings**

The standard fittings for the motor are no12 JIC for flow and no6 JIC for drain. Flexible hoses are required.

The pump suction/blow selection is achieved by two hydraulic cylinders **that must be connected in parallel from a single control valve**. The standard fittings are no4 JIC. The cylinder bodies move with the pump body and flexible hoses are required.

The pump is configured for correct rotation when the hydraulic supply is connected to the "A" port of the Volvo motor and the return line to the "B" port. (The impeller will not turn running in the reverse direction when a Volvo Protector is fitted.)

In order to avoid pressure losses it is mandatory that a minimum of 1/2" bore pipework or hoses is used on the flow and return lines to the motor, 3/4" or larger is recommended.

It is mandatory that the drain connection from the motor back to tank is a minimum of 3/8" bore. The drain line should return straight to tank without restriction. It is permissible to connect the drain line back into a larger bore drain manifold which has been correctly sized to accommodate all drains attached to it.

 <b>DANGER!</b>	<p><i>It is not permissible to common up the drain line with return flow lines.</i></p> <p><i>It is strongly recommended that self sealing quick disconnects are not used on the drain line. Use of such fittings is at the users risk. If such a connection is used then it is mandatory to ensure that it has been fully and correctly fitted prior to starting the motor. Failure to do so may result in pressurisation of the motor casing which could explosively burst under system hydraulic pressure with considerable risk of personal injury.</i></p> <p><i>To avoid shock loading the motor when the supply is stopped it is essential to provide the check valve shown. This will allow the motor to run down steadily rather than coming to an abrupt stop.</i></p>
---	--

Specification for check valve.

1/2" check valve, cracking pressure 0.5 bar.

Recommended valve

Tritech Volvo Protector AZ10-VP10 (see Appendix)  
 Or Integrated Hydraulics FPR-1/22-0.5

 <b>DANGER!</b>	<p><i>Never use the same size fitting for pressure hoses and the case drain. If this is done there is a significant risk of incorrect hook-up causing pressure to be applied to the motor case which could cause the case to burst explosively with high risk of personal injury.</i></p>
---	---

**Required Hydraulic Flow**

For the Volvo F11-10 motor. The required flow may be chosen in conjunction with the performance curves supplied. The maximum dead head water pressure is a function of the impeller speed which is directly related to the hydraulic flow.

If limiting dead head pressure is important to protect the structural integrity of the anchor then this may be achieved by limiting the hydraulic flow or by setting the suction relief valve or by a combination of both. Limiting hydraulic flow will also reduce the maximum available water flow. This will be particularly significant if the flow limit is imposed by a restricting valve rather than a direct flow control valve since the hydraulic pressure will also be severely reduced.

Usually anchors pull in quite progressively so the differential pressure builds quite slowly and control can be achieved by manually stopping the pump when the anchor has reached the correct position or the pressure limit has been reached.

## Testing In Air

	<p><i>Under no circumstances must the hydraulic flow be allowed to exceed 70l/min when testing in air. There is no back pressure on the impeller to control its speed and many vehicle hydraulic system are capable of higher deliveries when there are no thrusters running. Over speeding the motor can cause catastrophic failure. To avoid excessive wear and the possibility of ceasing the impeller and body, the unit should not be run for extended periods out of the water (More than 30 seconds). This is especially true when the unit is new. Absence of water around the plastic removes the natural cooling mechanism and may result in the moving parts becoming misshapen due to heat.</i></p>
---	---

### Hydraulic motor shaft seals

Volvo produce two seals.

"N" type coloured blue and

"H" type coloured red.

The "H" type is a high pressure seal and fitted as standard on the AnchorZip.

Replacement of seals with anything other than a genuine Volvo seal (or Tritech supplied seal) will invalidate warranty.

## CORRECT OPERATION OF THE ANCHORZIP PUMP

Damage will occur to the impeller and pumping cavity if it is used to pump sharp silt or sand over an extended period.

This may occur

- a) if the seabed into which the anchor is inserted has erupted inside the anchor allowing significant quantities of material to be drawn down the sides and then through the interior of the anchor. This will mean that the anchor has been excavated into position rather than properly drawn in.
- b) if the anchor is drawn too far into the seabed and pumping is maintained.

The pictures below show these effects.

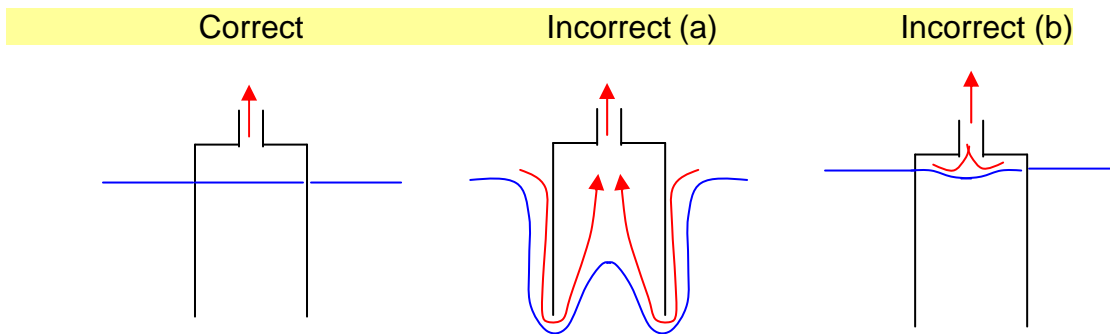

Allowing this to happen is not only detrimental to the pump, but more seriously in case a) is highly detrimental to the security of the installed anchor. In both cases installation will take much longer than normal.

### Achieving differential suction pressures in shallow water

The impellor based AnchorZip pump relies on a head of water above the pump in order to achieve differential suction pressures otherwise cavitation will occur. The drawings on the following page serve to illustrate the effect of depth and achievable differential pressures as a result.

*This page serves as a key and guide to the following page*

$\Delta P$  is the differential pressure created by the pump between the ambient sea pressure and the enclosed tank

$P_A$  is absolute pressure

#### In Suction mode

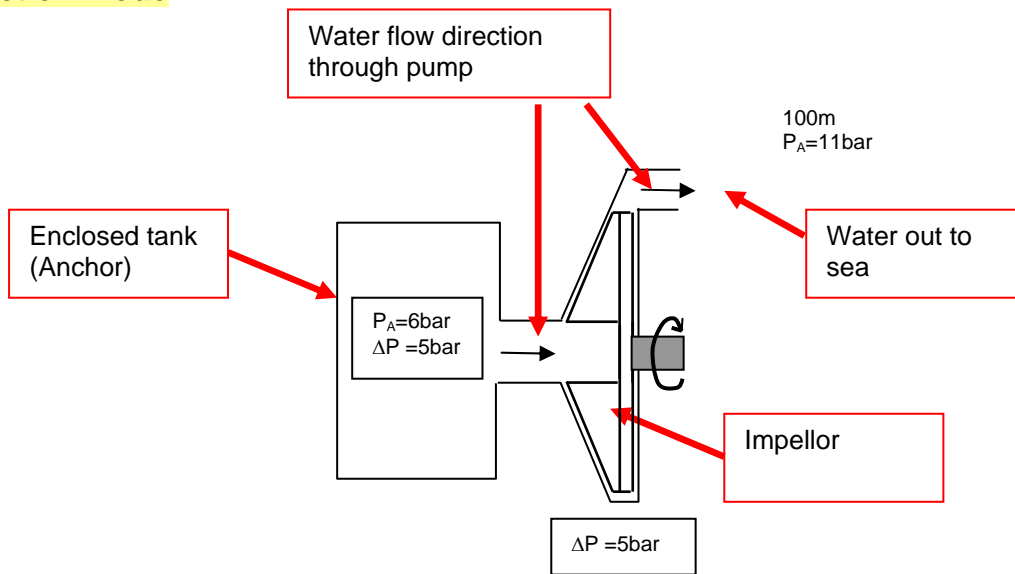

#### In Blowing mode

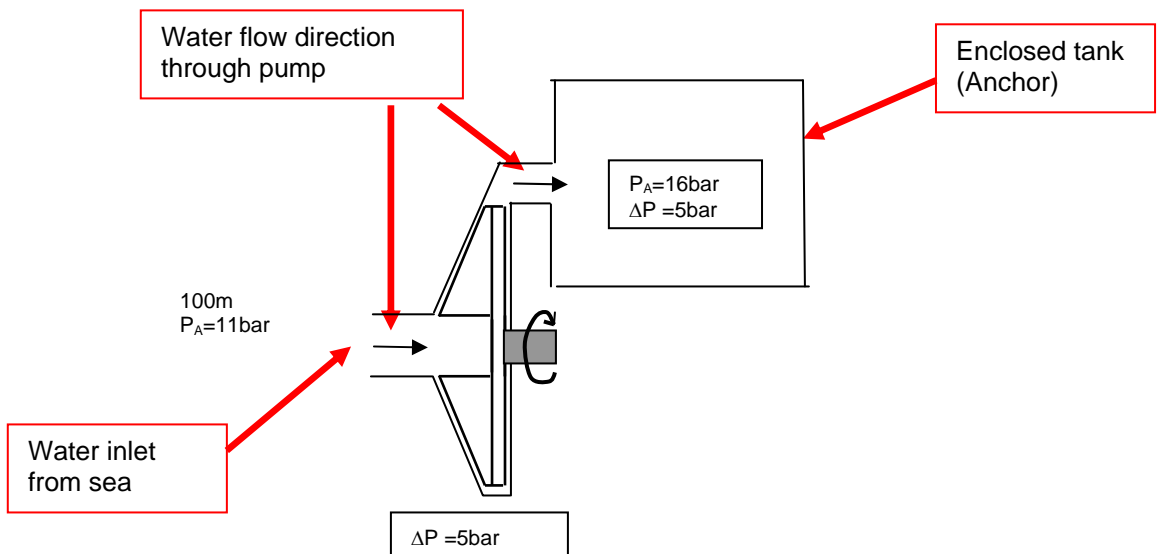

**Example : Depth versus suction capability**

With pump set for a differential pressure of 5 bar with pump at :- Surface, 30m and 100m depths

Air

Water

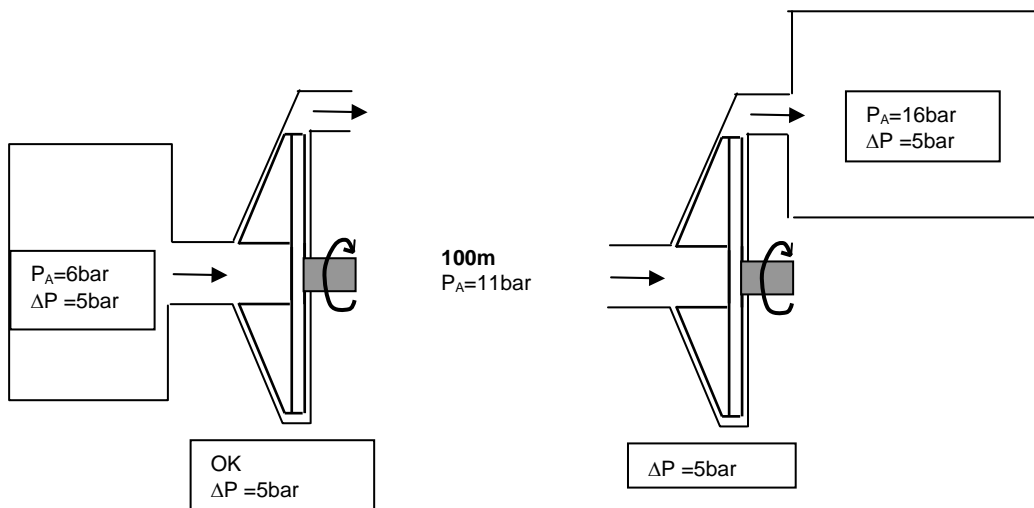
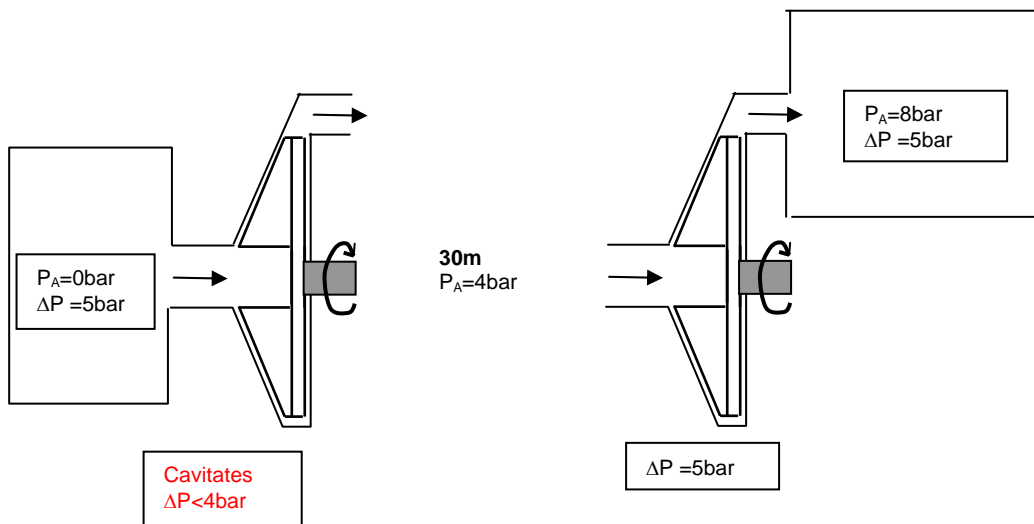
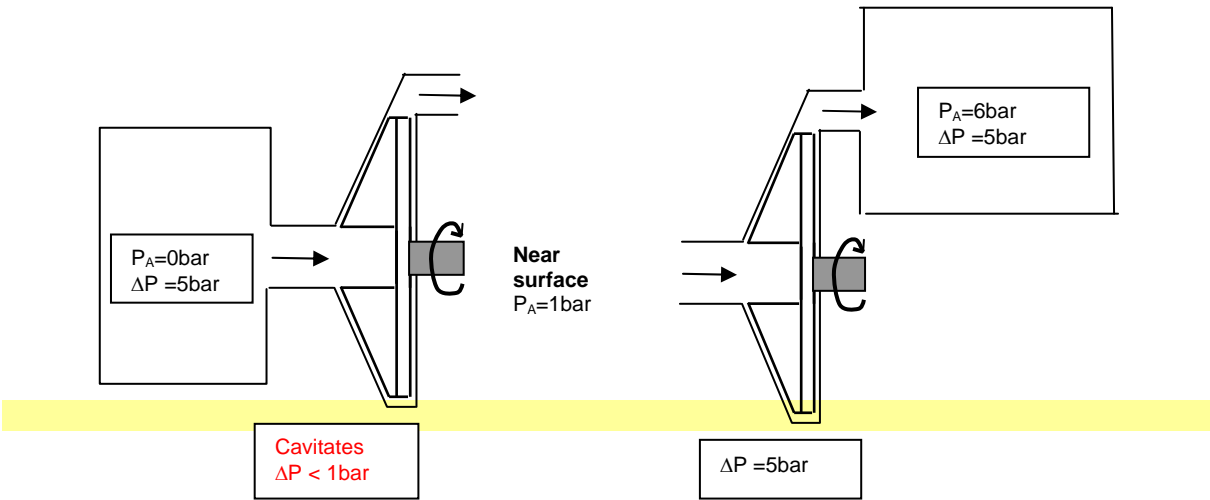

## MAINTENANCE

The pump is designed for low maintenance operation.  
The main materials are stainless steel and wear resistant polymer plastics.

The only internal moving parts that may need maintenance are

- The power pump impeller

- The hydraulic motor

- The reversing slide mechanism and actuators

### Basic maintenance procedures

#### Pre- Dive

Visual check for external damage

- Check hoses are secure

- Check mountings are secure

Inactive time

If the vehicle will be inactive for more than 48 hours or at demob

Run a fresh water hose into the clean water suction inlet for a few minutes, then spin the hydraulic motor for about 15 seconds (taking care not to allow it to over speed).

#### Storage

If the pump is removed from the vehicle, then the hydraulic ports should be blanked off with metal caps and the unit washed out with fresh water.

Leave the actuator valves in their retracted position.

Visually inspect the leading edges of the power pump impeller for damage and erosion.

Up to four blades may have leading edge damage of 5mm width and 4 mm depth before replacement becomes essential.

If the majority of leading edges are eroded more than 3.5mm back from the bore of the inlet nozzle then consideration should be given to replacing the impeller.



## Basic Fault Finding

### Poor performance

Check that the clean water suction strainer is clear and that there are no blockages in the hose.

Check that there is no sign of any suction hose in use collapsing under suction.

Check the operation of the reversing system for full stroke.

Check that the hydraulic motor runs freely without excessive noise or vibration.

Check that the hydraulic flow meets the specification.

## Dismantling

 <p><b>CAUTION</b> !</p>	<p><i>Before carrying out any maintenance work on the pump unit it is essential to ensure that the vehicle hydraulic system has been depressurised including compensation pressure.</i></p>
--	---

### Reverse valve actuators

The reverse valve actuators are retained by set screws through the spherical joints at each end of each cylinder. Seal kits are available for the cylinders should replacement become necessary.

### Relief valve slipper ring and setting relief pressure

Earlier models of the AnchorZip 10 pump had a standard interface block allowing suction relief over a pressure range of 0.95 to 4.1 bar, configurable by selecting different quantities of weak and strong springs. For pressures above 4.1 bar a modified interface block was required which clamped the relief valve shut and to allow higher pressure to be achieved without relief.

The latest version of the AnchorZip 10 removes the need for the modified interface Block by introducing a new High pressure Valve ring and with this valve ring in conjunction with the existing Low Pressure Valve ring can allow a range of pressure relief from 0.81 to 9.27 bar. This can all be done simply by varying the quantities of the same spring strength. The interface block supplied now has an o-ring groove so that the higher pressures can be better achieved

***This document will describe the procedure to adjust the pressure relief setting on the latest version pump only.***

### Setting relief pressure

The relief interface block (item 5) containing the valve ring is held in place by the slide bars mounted to the pump body and the hydraulic actuators. It may be removed by undoing the bolts securing the actuator spherical joints to the valve bar (item 8), leaving the interface block free to slide along the slide bars to the edge of the pump body. Due to the spring tension it will be quite stiff to move and can be edged along by tapping the interface block with a soft faced hammer.

	<p><i>The assembly is spring loaded. Great care must be exercised not to remove this item without first clamping the ring to the interface body.</i></p>
---	--

Once the interface block has reached the edge of the main block it should be very carefully knocked until the valve ring (item 6) is visible by about 12mm. A G-clamp should then be fastened around the block and exposed part of the valve ring.

The interface block can then be moved again very carefully until 60% of the valve ring is exposed. Two further G clamps are then applied across the diameter of the valve ring. The unit can then be fully removed, and the G clamps carefully released to de-energise the springs.

Springs must always be fitted in a symmetrical pattern.

Identify and select the correct valve ring for the pressure relief range required



Low Pressure Valve Ring

Using the LP Valve Ring

Spring C0480-074-2250S	Number of Springs	Relief Pressure
		bar (psi)
	3	0.81 (11)
	4	1.08 (15)
	6	1.62 (22)
	8	2.16 (29)
	9	2.43 (33)
	10	2.70 (37)
	12	3.24 (44)

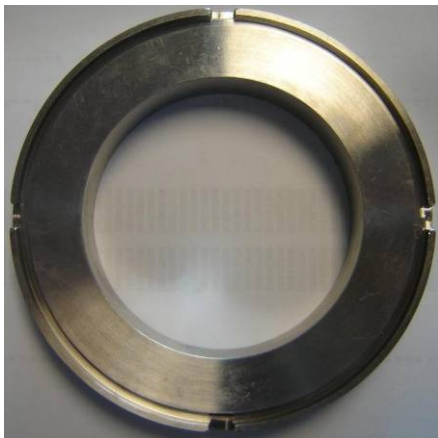

High Pressure Valve Ring

Using the HP Valve Ring

Spring C0480-074-2250S	Number of Springs	Relief Pressure
		bar (psi)
	3	2.32 (31)
	4	3.09 (42)
	6	4.64 (63)
	8	6.18 (84)
	9	6.95 (93)
	10	7.73 (105)
	12	9.27 (127)

**Assembling the Interface Block**



**Picture 1.**

Lightly grease the TI-BS622 O-ring and place it in the valve ring 'O'-ring groove see Picture 1.

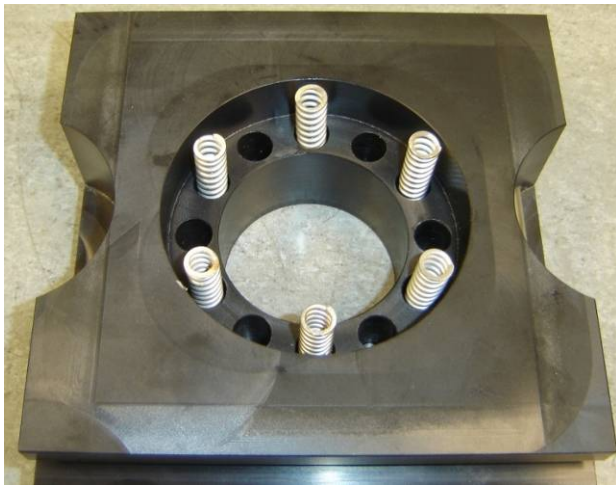

**Picture 2.**

On the Interface block place the correct quantity of C0480-074-2250S springs symmetrically in the holes provided see the table above for spring selection and picture 2.

Then place the valve ring over the springs and tighten down using the G clamps refer to picture 3 for positioning.

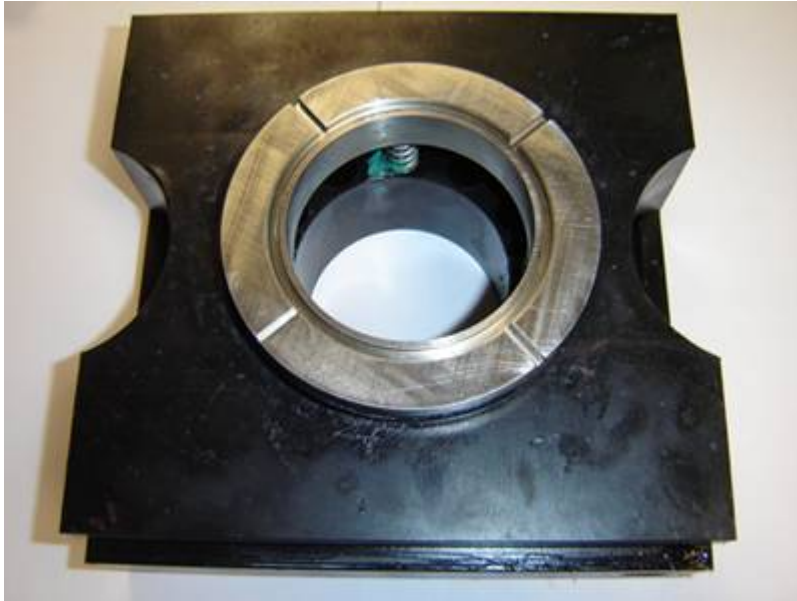

**Picture 3.**

Compress the valve ring until flush with the block face and mount the interface block on the anchor zip. Carefully remove the G clamps as the block slides into position. To move the block to its final position tap the block with a soft faced hammer. Once in position re-attach the actuators as shown in picture 4.

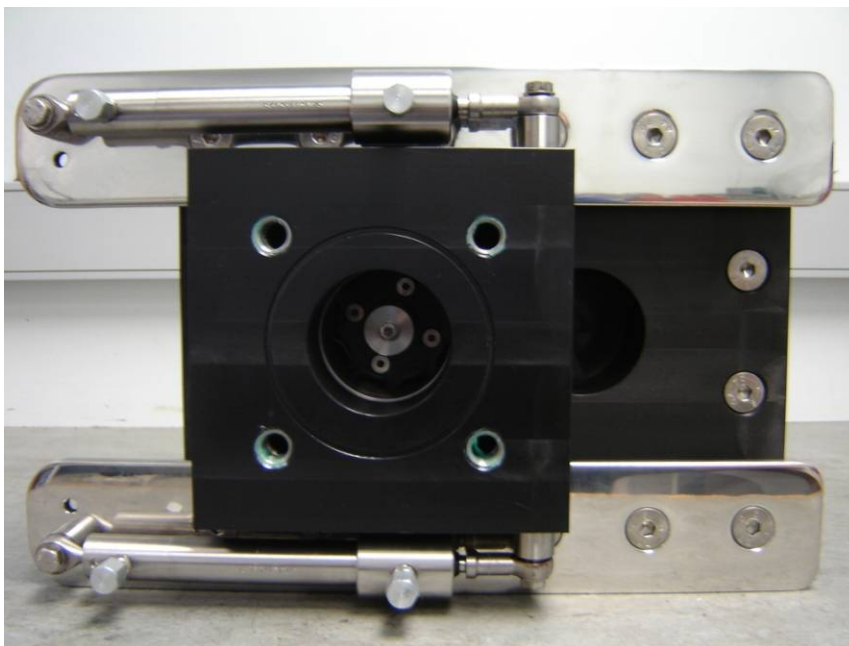

**Picture 4.**

Apply an anti-seize compound to the M16 threaded inserts to aid lubrication when fitting the mating connection.

Grease and fit the BS156 o-ring to the interface block if required.

## Hydraulic Motor and Impeller

In order to remove the motor and impeller it is necessary to completely disassemble the pump.

First remove the actuator cylinders and interface block as above, remove all the bolts holding the guide bars and case parts together and then split the case. The impeller can then be removed from the pump shaft by undoing the set screw at the centre of the impeller boss, undoing the bolts securing the Volvo motor, and easing the motor away from the top case which will in turn pull off the impeller.

When reassembling apply some anti-seize grease to the motor shaft before fitting the impeller. Press the impeller boss onto the shaft right up to the shoulder. Assemble the retainer onto the shaft end and secure the setscrew using a small quantity of Loctite. If the impeller has been removed from its mounting boss, replace the impeller on the boss and secure the four countersunk screws with Loctite.

# PARTS DIAGRAM

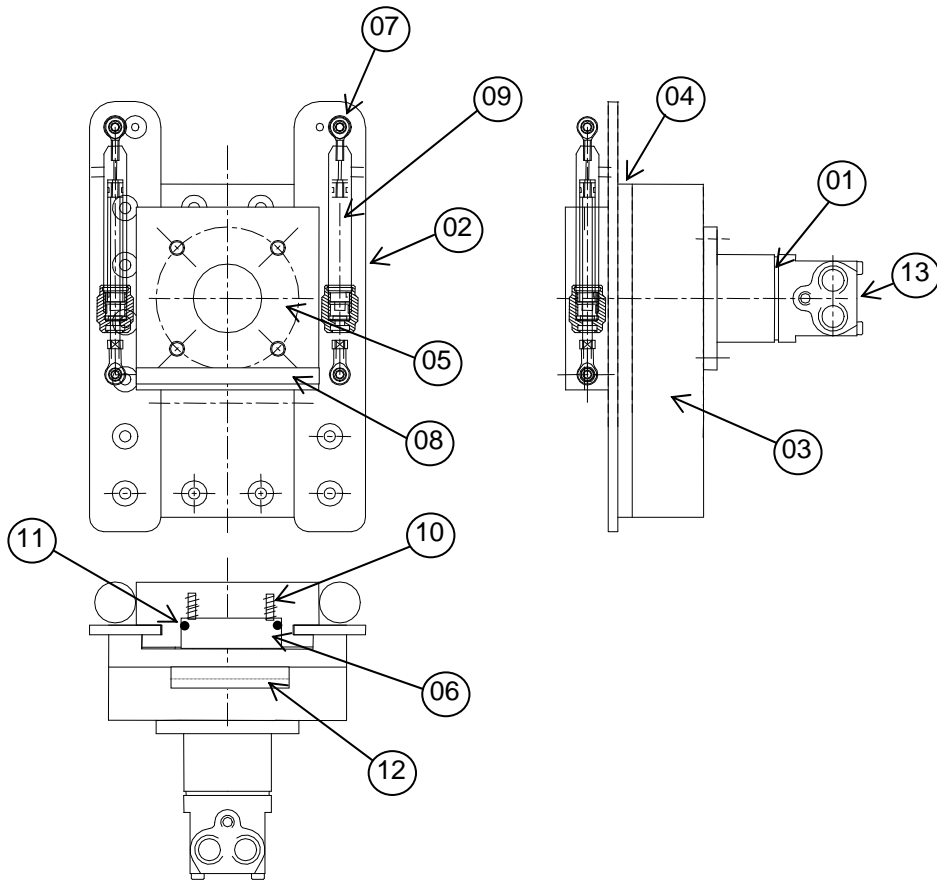

**Parts List**

Item	Qty	P/N	Description
1	1	TI-F11-10-99098P	Motor (Volvo F11-010-MB-CHK-000)
2	2	TI-AZ10-002B	Slide Bar
3	1	TI-AZ10-003B	Main Case
4	1	TI-AZ10-004A	Case Top
5	1	TI-AZ10-003-01A	Interface Block
6	1	TI-AZ10-006-LP	Valve Ring - Low Pressure
(6	1	TI-AZ10-006-HP	Valve Ring - High Pressure)
7	4	TI-AZ10-007A	Spacer
8	1	TI-AZ10-008A	Valve Bar
9	2	TI-10/110-0-RSE-C	110mm stroke Actuator
10	12	TI-C04800742250S	Springs
11	1	TI-BS622NI70	'O' Ring
12	1	TI-ZJU-8907	Zip 120mm Impeller assy.
13	1	TI-3002-01-000	Volvo Protector Assembly

Hardware list

Qty	Description
12	M12x120 c'sunk socket head screw s/s
4	M12x120 c'sunk socket head screw s/s
2	M12x120 c'sunk socket head screw s/s
18	M12 Nyloc nut s/s
18	M12 plain washer s/s
2	M8x50 hex head bolt s/s
2	M8 Nyloc nut s/s
2	M8x40 hex head bolt s/s



## APPENDIX 1

### Tritech Volvo Protector.

The Anchor Zip 10 pumps are factory fitted with the Tritech Volvo Protector.

**Note:** The BSP Volvo ports are no longer available with the Tritech Volvo Protector fitted.

### The Volvo Protector Assembly

#### Part No.3002-00-000, comprises: -

- 1 off Motor Protector Block, 316 S/S, Part No.3002-01-001
- 2 off 3/4"-14 BSP Male to 12 JIC Male Connector, 316 S/S, Part No.3002-00-002
- 1 off 3/8"-19 BSP Male to 6 JIC Male Connector, 316 S/S, Part No.3002-01-003
- 1 off High Carbon Chrome Alloy Ball Bearing, Part No.90100-10
- 1 off 6P50 Hex Plug c/w Seal, 316 S/S, Part No.89401
- 2 off 12 JIC Female Cap, C/S, Part No.89202
- 1 off 6 JIC Female Cap, C/S, Part No.89201
- 1 off 3/8" Self-Centre Dowty, 316 Ring, Part No.89300
- 2 off 3/4" Self-Centre Dowty, 316 Ring, Part No.89301
- 1 off O-ring 20mm X 2mm, Part No. TI-BSI-0200-20NI70
- 2 off O-ring 32mm X 2mm, Part No. TI-BSI-0320-20NI70
- 1 off Compression Spring, 316 S/S, Part No.D21770

The procedure to fit a Tritech Volvo Protector is as follows:

Remove any existing port fittings from the F11 – 10 Volvo motor. Ensure that the top face of the F11 – 10 Volvo motor is free from any debris i.e. paint, dirt and grit etc. Clean and degrease surface.

Place the three Dowty washers onto their respective hydraulic fittings. Place the motor protector over the fittings and position the other three O-rings as shown below in Diagram 2.



**Diagram 2.**

Once the fittings have been inserted and tightened, blanking caps should then be fitted. The motor protector assembly is fitted to the motor as shown in Diagram 3.

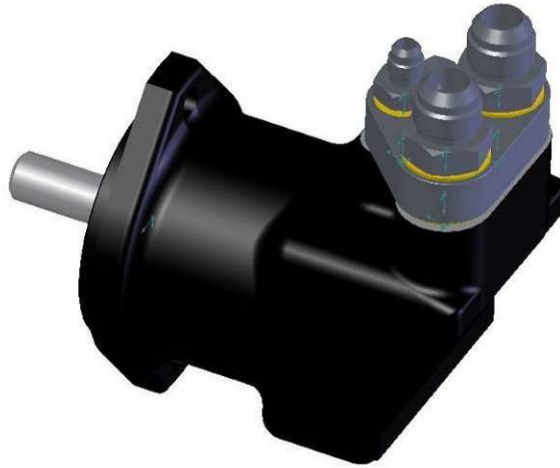

**Diagram 3.**



**DANGER!**

*Never use the same size fitting for pressure hoses and the case drain. If this is done there is a significant risk of incorrect hook-up causing pressure to be applied to the motor case, which could cause the case to burst explosively with high risk of personal injury.*

## APPENDIX 2

### Performance Curves

AnchorZip 10  
120 Impeller Bare Pump Characteristic

